

| No. | Rev. | Revision Record | Date |
|-----|------|-----------------|------------|
| △ | A0 | 首次发行 | 2019-08-02 |
| △ | A1 | FPC缩短70mm | 2019-11-15 |
| △ | A2 | 液晶屏更改 | 2019-11-27 |
| | | | |

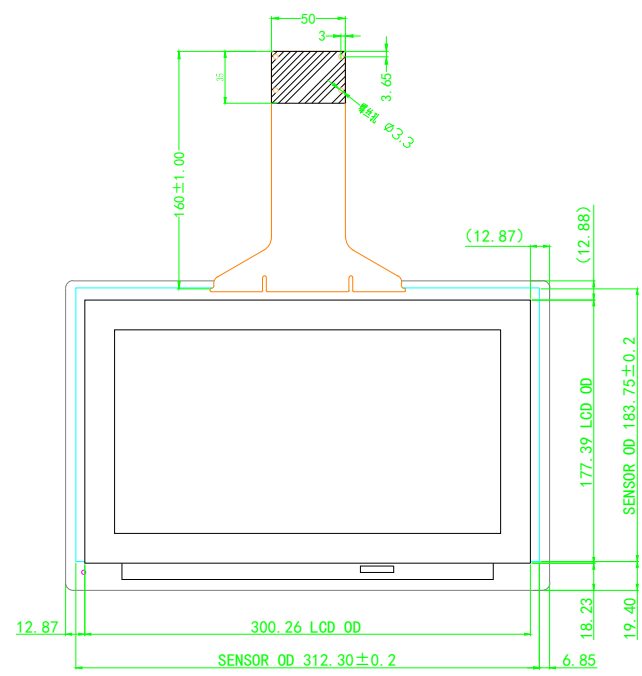
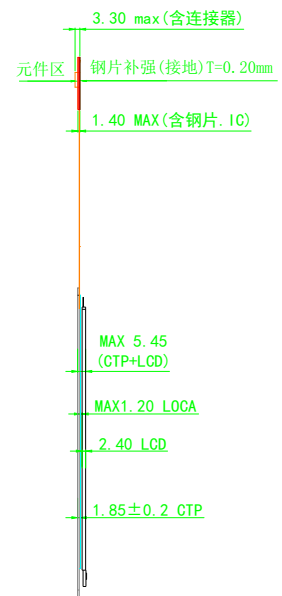
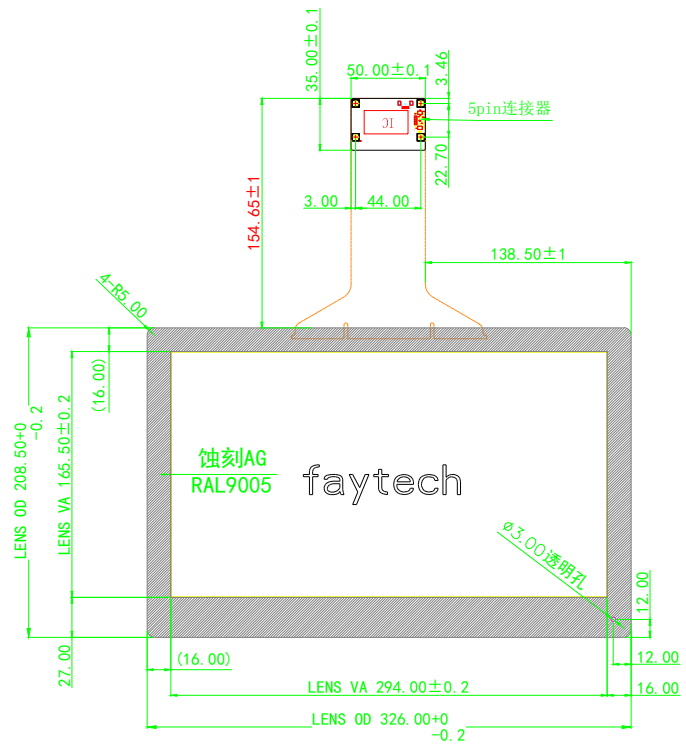

- 技术参数:
- 1、贴合方向如上图所示;
 - 2、胶层厚度1.2mm (MAX);
 - 3、贴合方式: 胶水贴合;
 - 4、贴合位置: 以视窗居中;
 - 5、未注明公差为±0.30mm;

| 贴合图 | | faytech 深圳市飞帆泰科技有限公司 SHENZHEN FEIFANTAI TECHNOLOGY CO., LTD | | | |
|-------|--------|--|-------------------|------|------------|
| Sheet | 1 of 1 | NAV NO. | 3030502619 | | |
| UNIT | mm | Model NO. | P133PFHM-N52-0B03 | | |
| REV. | A1 | Part NO. | 13.3寸 | | |
| Scale | FIT | Designed | Bella | Date | 2019-11-27 |
| | | Checked | Kelvin | Date | 2019-11-27 |
| | | Approved | | Date | |

Autodesk

Autodesk

B

A