

IPCCBAA311DPR

v1: GL: 3030520634 | EU: 4010080382



Pictures show sample configurations, real product may vary.

PC/MONITOR SYSTEM

Processor	Amlogic A311D
Chipset	Quad-Core Cortex-A73 + Dual-core Cortex-A53
Standard Operating System	Android 9
OS Available on Request (additional fee)	Linux Ubuntu 22.4, Debian 12 *
RAM Size	4 GB LPDDR4
EMMC Size	64 GB eMMC 5.1
GPU	Mali G52 MP4
NPU	5.0Tops
Loudspeaker	2x 2W
Wifi + BT	RTL8821 + Bluetooth 4.0
HDMI	1
SD Card Slot	1
Audio In / Out	1 (MAX98090 audio chip)
USB 2.0	4
USB OTG	1
Ethernet Network (10/100/1000 Mbit/s)	1
Serial Port RS232 (RX / TX only)	1
Serial Port RS485 (pin A (+) / pin B (-))	1

SERIAL (RS232) PIN DEFINITION

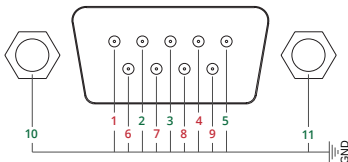

2	RXD1
3	TXD1
5	GND
10	GND
11	GND

ENVIRONMENTAL CONDITIONS

Operation Temperature	-10°C to 60°C
Storage Temperature	-20°C to 60°C
Humidity Range	10% to 90%

CERTIFICATIONS

CE Certificate	Yes
FCC Certificate	Yes

* faytech Tech Co., Ltd. is not affiliated with Debian. Debian is a registered trademark owned by Software in the Public Interest, Inc.

CHASSIS

Case Design	Standard Aluminum
Case Size	Large
IP Protection	IP40
Case Color	RAL9004 (Black)
Case Coating	Powder Coating
Case Material	Aluminum
Case size L x W x H [mm]	212.0 x 173.2 x 34.0
Mounting	VESA 100 x 100
	Screwhead holes (20x14 cm)

ACCESSORIES

Power Adapter	100-240V ACDC active switching; 12V DC-Out
Wifi Antenna	RP-SMA female
Short Instruction Manual	Yes
Power over Ethernet (PoE)	No, available upon request

POWER

Power Indicator	Green LED
Working Power	9-36V
Power Consumption	6.4W
Stand-By Consumption	<1W

WEIGHT & PACKAGING

Net Weight	~2.20 kg est.
Gross Weight	~3.20 kg est. (incl. Cartonage)
Packaging Material	100% recyclable cardboard and polyethylene (PE)
Packaging Size L x W x H [mm]	255.0 x 312.0 x 41.0

INTENDED USE/APPLICATION

The device is to be used as an Industrial PC for indoor use connected to any monitor for control panel, digital signage, way-finding, POS and similar applications.

Direct sunlight might increase the device temperature beyond the allowed storage and operation conditions. Therefore the devices must be protected against direct sunlight. Devices operated or stored outside the specified temperature ranges are not covered by warranty.

DIMENSIONS

INDUSTRIAL PC ARM A311D (LARGE BOX PC)

Pictures show sample configurations, real product may vary.

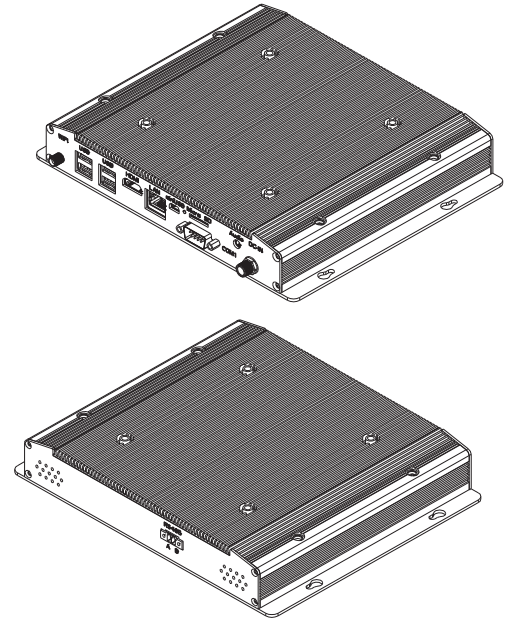
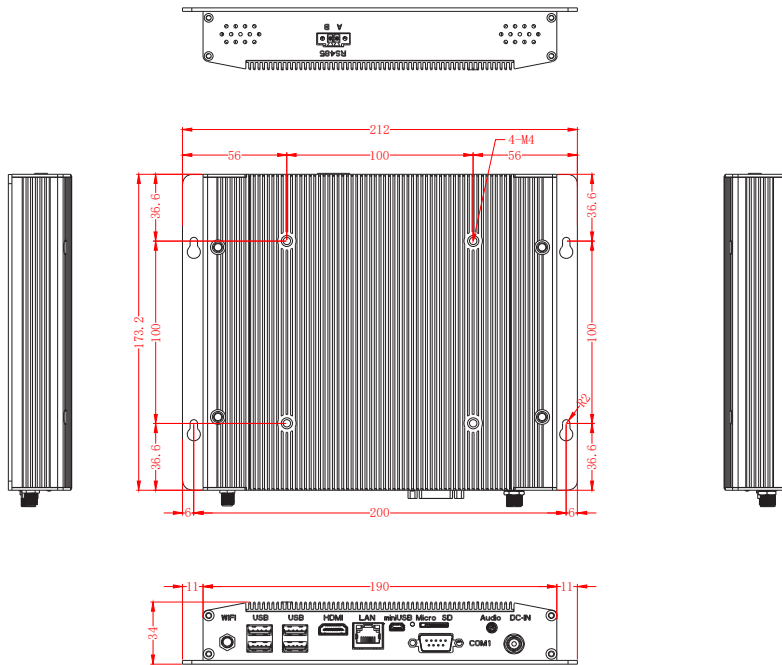

UPDATE NOTES:

Version:	Changes:
v1	First version